



Trimble AG25 Antenna

PRECISION GNSS ANTENNA FOR LAND APPLICATIONS

Trimble AG25 GNSS antenna is designed to support high precision land applications. Designed for quick installation, the Trimble AG25 antenna is equipped with a magnetic attachment for simple mounting onto any metal surfaces.

COMPREHENSIVE GNSS SUPPORT

The Trimble AG25 antenna offers full support for current and near-future GNSS signals from GPS, GLONASS, Galileo, BeiDou, QZSS, IRNSS, OmniSTAR, Trimble RTX and SBAS.

Key Features of Trimble AG25:

- ▶ Equipped with a mag switch to allow users to change between MSS wideband and narrowband
- ▶ Magnetic mount allows for the easy install and removal of the antenna

Key Features

- ▶ Comprehensive GNSS support, including GPS modernization signals, GLONASS, BeiDou, Galileo, QZSS and IRNSS
- ▶ OmniSTAR and RTX Support
- ▶ Supports MSS narrowband and wideband
- ▶ Rugged and 100% humidity proof



Trimble AG25 Antenna

TECHNICAL SPECIFICATIONS

- Comprehensive GNSS Tracking:
- GPS: L1, L2, L5
 - GLONASS: L1, L2, L5
 - Galileo: E1, E5a, E5b, E6
 - BeiDou: B1, B2, B3
 - QZSS: L1, L2, L5, LEX
 - IRNSS: L5
 - SBAS: WAAS, EGNOS, GAGAN, and MSAS
 - MSS: OmniSTAR, Trimble RTX
- Magnetic switch for narrowband and wideband
- Wideband mode: 1525 - 1614 MHz
 - Narrowband mode: 1555 - 1608 MHz
- MTBF >5,000 hours

Compliance CE compliant including ISO 7637, 2011/65/EU (RED), EN 55022, E-Mark and RoHS, FCC, ICES and RSS compliant

PHYSICAL AND ELECTRICAL SPECIFICATIONS

Dimensions 16.13 cm diameter x 7.5 cm height
 (6.35 in diameter x 2.95 in height)

Weight 0.57 Kg (1.26 lb)

Input Voltage 3.4 V DC to 12 V DC

Input Current <130 mA

Signal Gain 48 dB

Signal Connector TNC Female

Mounting Magnetic Mounts

ENVIRONMENTAL QUALIFICATIONS

- Operating Temperature . . -40 °C to +70 °C (-40 °F to +158 °F)
- Humidity 100% humidity proof, fully sealed, IP67
- Shock and Vibration
- Tested and meets the following environmental standards:
- Shock MIL-STD-810-F to survive a 2 m (6.56 ft) drop onto concrete
 - Vibration MIL-STD-810-F on each axis

PART NUMBER

99038-00-INT Trimble AG25 Antenna
 Specifications subject to change without notice.

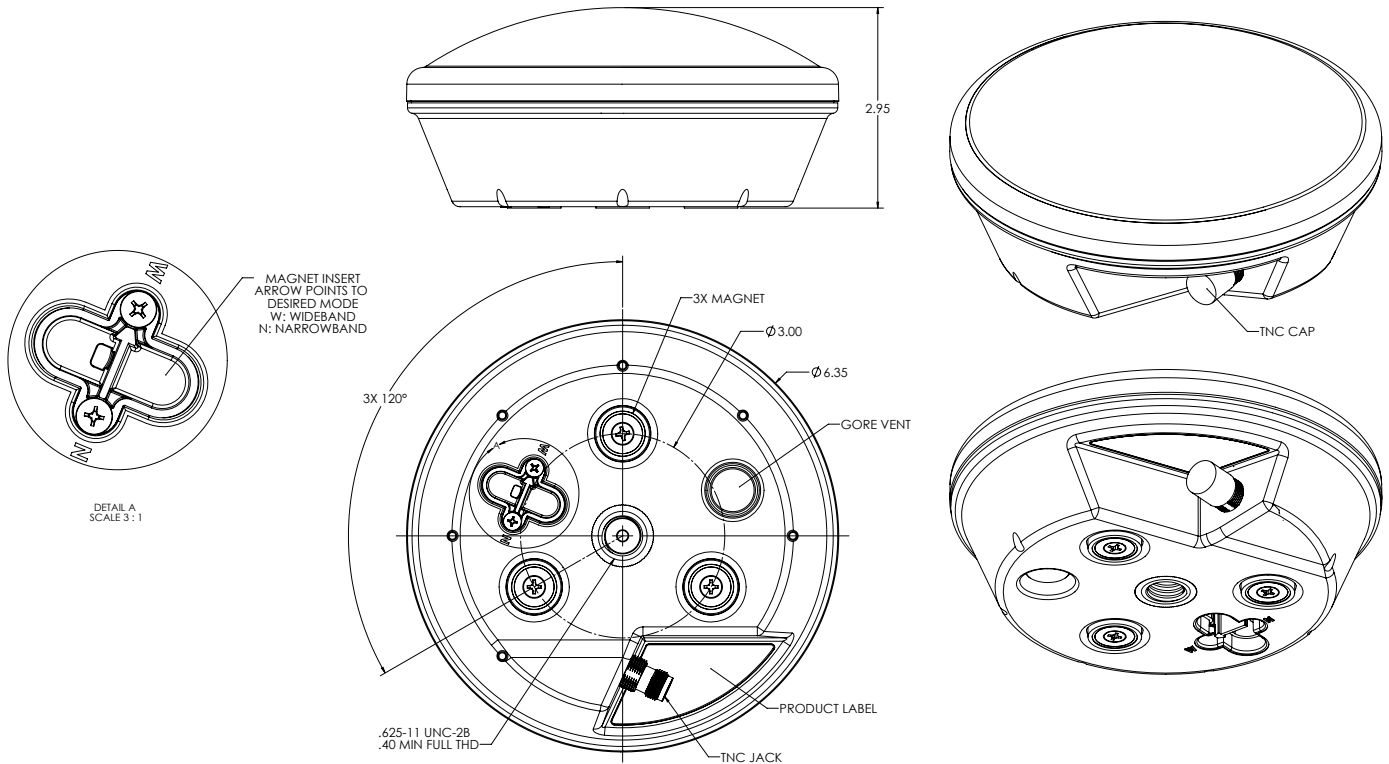

TRIMBLE
 Integrated Technologies
 935 Steward Drive
 Sunnyvale, CA 94085



Contact NavtechGPS for product details. www.NavtechGPS.com
 +1-703-256-8900 • 800-628-0885 • info@navtechgps.com

© 2018, Trimble Navigation Limited. All rights reserved. Trimble logo are trademarks of Trimble, registered in the United States and in other countries. All other trademarks are the property of their respective owners. (07/18)

