



1.2G-MINI-GNSSX-XX-X SERIES ANTENNA

Ultra Lightweight Antenna for Multi-Frequency GNSS Reception

The 1.2G-Mini-GNSSX-XX-X is an ultra lightweight circularly polarized antenna for applications demanding a miniature solution. This multi-band, multi-frequency antenna offers Global Navigation Satellite System (GNSS) coverage in the GPS, GLONASS, Galileo and Beidou bands. For best performance, the 1.2G Mini GNSS antenna should be mounted to a metal ground plane to enhance its low frequency reception.

The 1.2G Mini GNSS antenna is available in passive and active (amplified) configurations. The active circuitry is designed to support a wide range of input voltages with ultra low current consumption for long battery life and low fuel consumption. The amplifier design includes dual-stage filtering for excellent performance, even with nearby interference sources. The passive design is ideal for installations where the antenna is located close to the receiver and eliminates any need to power the antenna.

BENEFITS

- Rugged yet lightweight at only 1.42 oz (40 grams) for easier portability and longer airborne time on station
- Low power consumption with only 25 mA current draw and a wide input voltage compatibility range
- Multi-frequency GNSS capable including GPS M-Code & P(Y) signals and Galileo with PRS for high accuracy positioning, navigation and timing

FEATURES

- Easy installation via two (2) thru mount holes
- Single connector for antenna output and DC power input



OPTIONS

RADOME COLOR	<ul style="list-style-type: none">• Gloss White• Lusterless Gray• Olive Drab Green• Lusterless Black• Desert Tan
CONNECTOR (FEMALE)	<ul style="list-style-type: none">• SMA
LNA GAIN	<ul style="list-style-type: none">• 28 dB LNA• 15 dB LNA• Passive

ELECTRICAL

Signal Support	
GPS	L1, L2, L5 C/A, P(Y), M-Code
Galileo	E1, E5a, E5b PRS
GLONASS	L1, L2
Beidou	B1, B2, B2a, B2b
NAVIC	L5
L-Band Correction	
Passbands	
Upper passband	1539 to 1610 MHz
Lower passband	1164 to 1252 MHz
VSWR	< 2.0:1
Impedance	50 ohms
Polarization	RHCP

MECHANICAL & ENVIRONMENTAL

Designed to:

Weight (typical)	1.42 oz (40 g)
Temperature	-55°C to +85°C
Altitude	40,000 ft
Random Vibration	20 Grms

TYPICAL LNA PERFORMANCE

LNA Gain	
A option	28 dB ± 3 dB
A15 option	15 dB ± 3 dB
P option	Passive
LNA Noise Figure	3.5 dB
LNA P1dB Out	+11 dBm
Input Power	+2.7 to +15.0 VDC 25 mA
Power Handling	1 Watt CW
Group Delay Ripple	< 8 ns
Differential Propagation Delay	< 3 ns

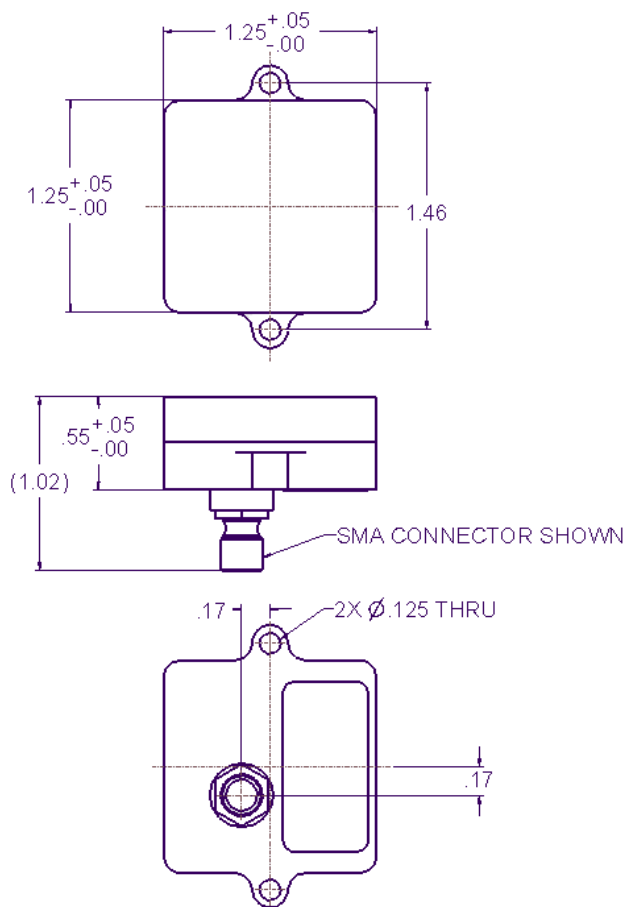

PART NUMBER DECODER

1.2G-Mini-GNSSX-XX-X



Contact NavtechGPS for product details. www.NavtechGPS.com
 +1-703-256-8900 • 800-628-0885 • info@navtechgps.com

