



+1-703-256-8900 or 800-628-0885
info@NavtechGPS.com
www.NavtechGPS.com

2G-MINI-GNSSX-XX-X SERIES ANTENNA

Miniature Antenna for Multi-Frequency GNSS Reception

The 2G-Mini-GNSSX-XX-X is a remarkably small, lightweight circularly polarized antenna solution for rugged applications. This miniature antenna offers multi-constellation, multi-frequency Global Navigation Satellite System (GNSS) coverage for high accuracy positioning, navigation and timing (PNT). The 2G Mini GNSS antenna is ideally suited for applications with tight size, weight, and power consumption (SWaP) constraints that need an accurate, high performance GNSS antenna.

The 2G Mini GNSS antenna is available in passive and active (amplified) configurations. The active circuitry is designed to support a wide range of input voltages with ultra low current consumption for long battery life and low fuel consumption. The amplifier design includes dual-stage filtering for excellent performance, even with nearby interference sources. The passive design is ideal for installations where the antenna is located close to the receiver and eliminates any need to power the antenna.



BENEFITS

- Rugged yet lightweight at only 3.2 oz (91 grams) for longer airborne time on station
- Low power consumption with only 25 mA current draw and a wide input voltage compatibility range
- Multi-frequency GNSS capable including GPS M-Code & P(Y) signals and Galileo with PRS for high accuracy positioning, navigation and timing

FEATURES

- Easy installation via four (4) blind threaded holes into the antenna base
- Single connector for antenna output and DC power input

OPTIONS

RADOME COLOR	<ul style="list-style-type: none">• Gloss White• Lusterless Gray• Olive Drab Green• Lusterless Black• Desert Tan
CONNECTOR (FEMALE)	<ul style="list-style-type: none">• SMA• TNC• Type N• TNC Bulkhead
LNA GAIN	<ul style="list-style-type: none">• 28 dB LNA• 15 dB LNA• Passive

ELECTRICAL

Signal Support	
GPS	L1, L2, L5 C/A, P(Y), M-Code
Galileo	E1, E5a, E5b PRS
GLONASS	L1, L2
BeiDou	B1, B2, B2a, B2b
NAVIC	L5
L-Band Correction	
Passbands	
Upper passband	1539 to 1610 MHz
Lower passband	1164 to 1252 MHz
VSWR	< 2.0:1
Impedance	50 ohms
Polarization	RHCP

MECHANICAL & ENVIRONMENTAL

Designed to:

Weight (typical)	3.2 oz (91 g)
Temperature	-55°C to +85°C
Altitude	40,000 ft
Random Vibration	20 Grms

TYPICAL LNA PERFORMANCE

LNA Gain	
A option	28 dB ± 3 dB
A15 option	15 dB ± 3 dB
P option	Passive
LNA Noise Figure	3.5 dB
LNA P1dB Out	+11 dBm
Input Power	+2.7 to +15.0 VDC 25 mA
Power Handling	1W
Group Delay Ripple	< 8 ns
Differential Propagation Delay	< 3 ns

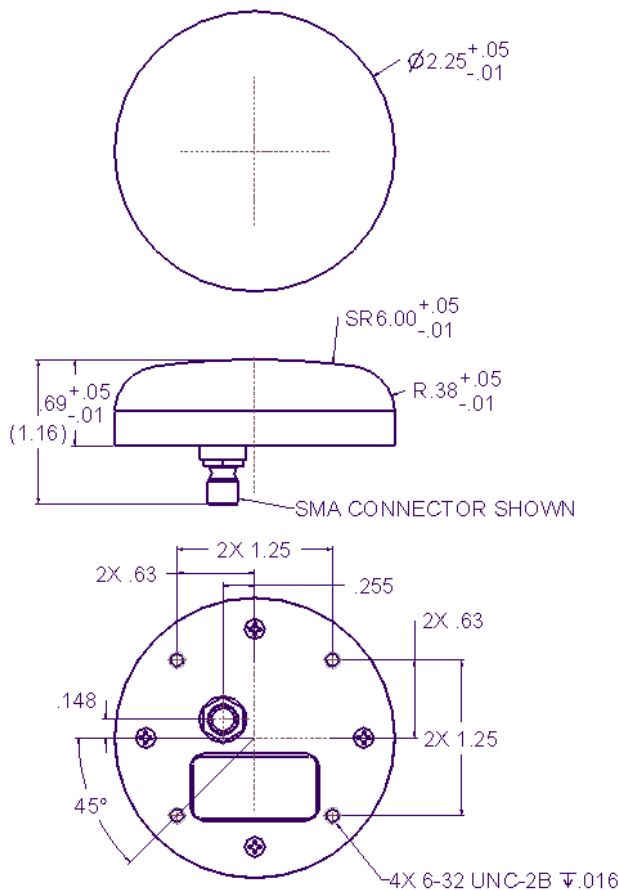

PART NUMBER DECODER

2G-Mini-GNSSX-XX-X

LNA Gain
A = 28 dB LNA
A15 = 15 dB LNA
P = Passive

Connector
S = SMA
T = TNC
N = Type N
TB = TNC Bulkhead

Color (PER AMS-STD-595)
1 = Gloss White #17925
2 = Lusterless Gray #36320
3 = Olive Drab Green #34094
4 = Lusterless Black #37038
5 = Desert Tan #33446



Contact NavtechGPS for product details. www.NavtechGPS.com
+1-703-256-8900 • 800-628-0885 • info@navtechgps.com

