



Contact us for product details and pricing

NavtechGPS

+1-703-256-8900 or 800-628-0885
info@NavtechGPS.com
www.NavtechGPS.com

When precision matters...™

A Tallysman Accutenna® TW2743 Magnet Mount Passive Iridium® / Active GNSS Antenna

The TW2743 employs Tallysman's unique *Accutenna* technology in a magnet mount, right hand circularly polarized antenna for the reception of all of the GNSS constellations (GPS L1/GLONASS G1/ Galileo E1/ BeiDou B1) plus Iridium: 1559 to 1626.5 MHz frequency band. It is specially designed to maximize the performance of Iridium™ Voice and Data Modems plus the upper GNSS band (1559 - 1606MHz)

The TW2743 is switchable between the passive Iridium and the active GNSS antenna by changing the input voltage to the antenna. When the input voltage is less than 5.5VDC, the antenna will engage the GNSS antenna. To invoke the passive Iridium antenna, an input voltage above 5.5VDC is required.

The TW2743 features a high performance dual-feed patch element that provides great axial ratio (4.5dB max, <1.5dB @ zenith) over the entire Iridium™ + upper GNSS frequency band, thus signals at the band edges remain truly circular, unlike the response of single feed antennas.

The TW2743 is housed in a compact, industrial-grade weather-proof, magnet mount enclosure, with threaded base holes for screw down attachment.



TW2743 Dimensions (mm)

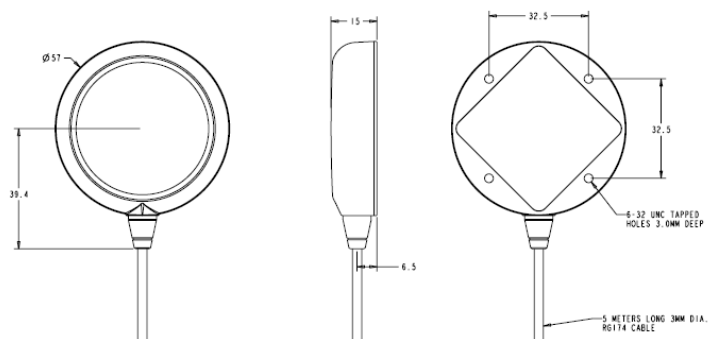

Applications

- Iridium™ Voice and Data Applications+ GNSS
- Sea & Land Container Tracking
- Military & Security
- Fleet Management & Asset Tracking
- Marine & Avionics Systems
- Law Enforcement & Public Safety

Features

- Custom high gain, 5 dBic dual-feed patch
- Great axial ratio, <1.5dB over full bandwidth
- 15 KV ESD circuit protection
- IP67 weather proof housing
- Robust Industrial grade enclosure
- Magnet or screw mount

Benefits

- Excellent circular polarized signal transmission
- Industrial temperature range
- Rugged Design
- Ideal for harsh environments
- RoHS and REACH compliant
- Remote SBD antenna



TW2743 Magnet Mount Passive Iridium® / Active GNSS Antenna Specifications

Vcc = 3V, over full bandwidth, T=25°C

Antenna

Architecture	Dual, quadrature feeds			
Antenna Gain (dBic, 100mm ground plane)	B1/E1	L1	G1	Iridium
	>3.5	>4.5	>5	>4.5
Axial Ratio (over full bandwidth)	≤1.5 dB			

Electrical

Frequency Bandwidth	1559 to 1626.5 MHz			
Gain (GNSS LNA)	21dB typ			
Cross Polarization Rejection	typically 20dB			
Out-of-Band Rejection	<1500MHz		>35dB	
	<1525MHz		>35dB	
	>1630MHz		>30dB	
Noise Figure (GNSS LNA)	3.5dB typ			
VSWR (at antenna)	<1.5:1 typ. 1.8:1 max.			
Supply Voltage	2.5 – 12VDC			
Supply current	14mA			
ESD Circuit protection	15 KV air discharge			

Mechanicals & Environmental

Mechanical Size	57 mm dia. x 15 mm H
Cable	RG174 / 50 cm, custom lengths optional
Operating Temp. Range	-40 to +85 °C
Enclosure	Radome: ASA plastic, Base: Zamak white metal
Weight	160 g
Attachment Method	Magnet or permanent (pre-tapped 4 x 6-32UNC)
Environmental	IP67, REACH, and RoHS compliant
Shock	Vertical axis: 50 G, other axes: 30 G
Vibration	3 axis, sweep = 15 min, 10 to 200 Hz sweep: 3 G

Ordering Information

TW2743 – Passive Iridium™ + Active GNSS antenna, 33-2743-xx-yyyy
 Where xx = connector type and yyyy = cable length in mm

Please refer to the Ordering Guide (<http://www.tallysman.com/wp-content/uploads/Current-Ordering-Guide.pdf>) for the current and complete list of available connectors.



36 Steacie Drive, Ottawa ON K2K 2A9 Canada

Tel +1 613 591 3131 Fax 613 591 3121 sales@tallysman.com

The information provided herein is intended as a guide only and is subject to change without notice. This document is not to be regarded as a guarantee of performance. Tallysman Wireless Inc. hereby disclaims any or all warranties and liabilities of any kind. © 2011 Tallysman Wireless Inc. All rights reserved. V1.1



Contact NavtechGPS for product details. www.NavtechGPS.com
 +1-703-256-8900 • 800-628-0885 • info@navtechgps.com