



LNFA1X4

Low Noise Filtered Amplified 1X4 Splitter

Technical Product Data



Features

- **Low Noise**
- **Amplified Unity Gain 0dB typical**
- **L1 GPS Filtered**
- **Extremely Flat Group Delay**
Less than 1ns variation
- **High Isolation Standard**
- **DC Blocked Outputs Feature 200Ω Loads**
- **Excellent Gain Flatness**

Description

The LNFA1X4 Low Noise Filtered Amplified GPS Splitter is a one input, four output device with 0dB nominal gain. The device features a low noise input section to establish an overall system noise figure. Excellent port-to-port isolation and unity gain are achieved by padded outputs. The device features excellent frequency selectivity around the L1 band to prevent interference from other high power radio frequency sources, such as cellular transmitter stations. The LNFA1X4 device will power itself and an external GPS antenna from a 5.0 VDC source connected on any of the RF Outputs. A “pick and choose” circuit is used to select only one DC input for power in the event that more than one 5v source is connected. The remaining DC inputs are switched to a 200Ω resistor to simulate antenna current draw. Contact GPS Networking Technical Support for any questions regarding standard or special configurations at salestech@gpsnetworking.com or 1-800-463-3063.

Electrical Specifications, $T_A = 25^{\circ}\text{C}$

Parameter	Conditions	Min	Typ	Max	Units
Freq. Range	Ant-J1, J2 -J4 50 Ω ; Ant-J2, J1, J3-J4 50 Ω ; Ant-J4, J1-J4 50 Ω	1.1		1.7	GHz
In/Out Imped.	Ant, J1, J2, J3, J4		50		Ω
Gain		-1.5	0.0	1.5	dB
Input SWR	All ports - 50 Ω			2.0:1	
Output SWR	All ports - 50 Ω			1.5:1	
Noise Figure	Ant – J1, J2, J3, J4 - 50 Ω ;		3.6	3.8	dB
Selectivity	$\pm 50\text{MHz}$, Ant – Any Output	40	45		dB
Amplitude Balance	J1-J2, J1-J3, J1-J4, J2-J3, J2-J4, J3-J4; Ant – J1-J4, 50 Ω			1.0	dB
Phase Balance	Phase (J1 – J2, J3, J4); Ant – J1, J2, J3, J4 - 50 Ω ;			1.0	deg
Output Isolation	J1 – J4, Ant - 50 Ω	36	40	50	dB
Group delay Flatness	$\tau_{d,max} - \tau_{d,min}$: Ant – J1, J2, J3, J4 - 50 Ω ;			1	ns
Req. DC Input V.	DC Input on J1, J2, J3 or J4	4.5	5.0	5.5	Vdc
P1 dB	Output Power @ 1dB Gain Compression (f = 1.5GHz)		-32		dBm
Current Draw (5v) ⁽¹⁾	Amplifier Current Draw, All ports - 50 Ω		12	15	mA

RF Connector Options		
Connector Options	CONNECTOR STYLE	CHARGE
	Type N-female	NC
	Type SMA-female	NC
	Type TNC-female	NC
	Type BNC-female	NC
	Other	Contact GPS Networking



Contact NavtechGPS for product details. www.NavtechGPS.com
 +1-703-256-8900 • 800-628-0885 • info@navtechgps.com

Part Number Configuration

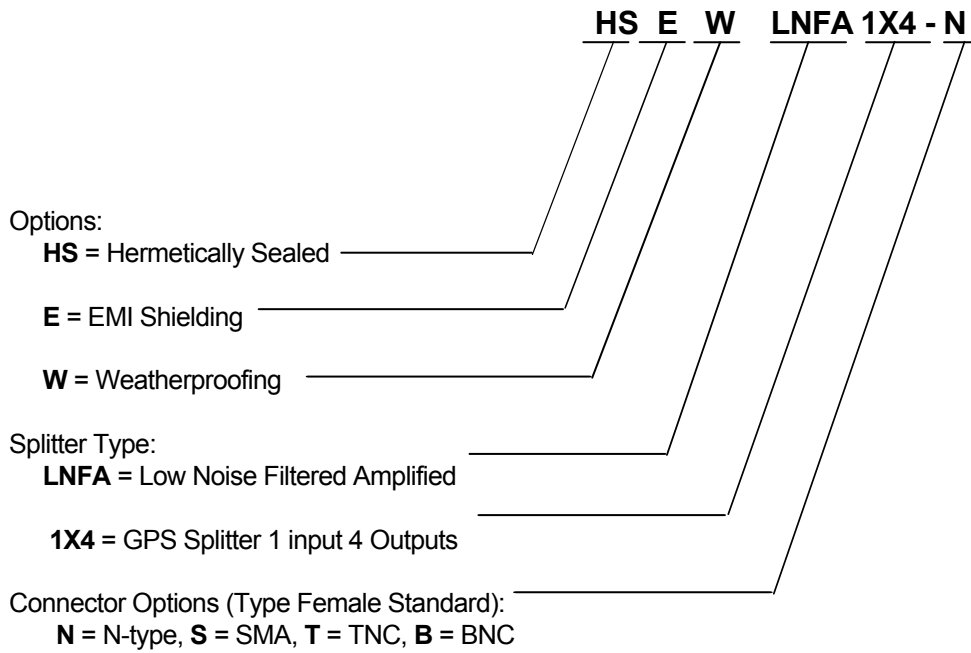

(Contact GPS Networking Technical Support at 719-595-9880 or salestech@gpsnetworking.com for any questions regarding non-standard configurations and corresponding part numbers)

Performance

LNFA1X4 (0dB or Unity Gain)

Input SWR (Ant. port) and Frequency Response: Ant. To J1, J2, J3, J4 (Typical, Type N connectors)

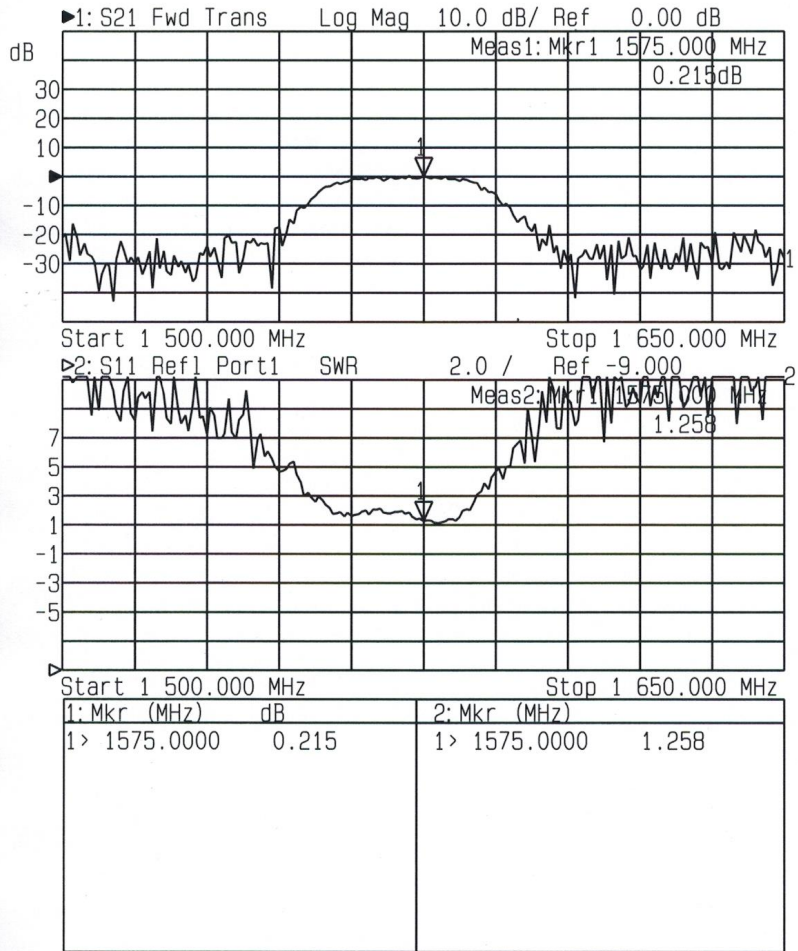

LNFA1X4:

Output Isolation (J1, J2, J3, J4) and Output SWR (J1 - J4) (Typical, type N connector):

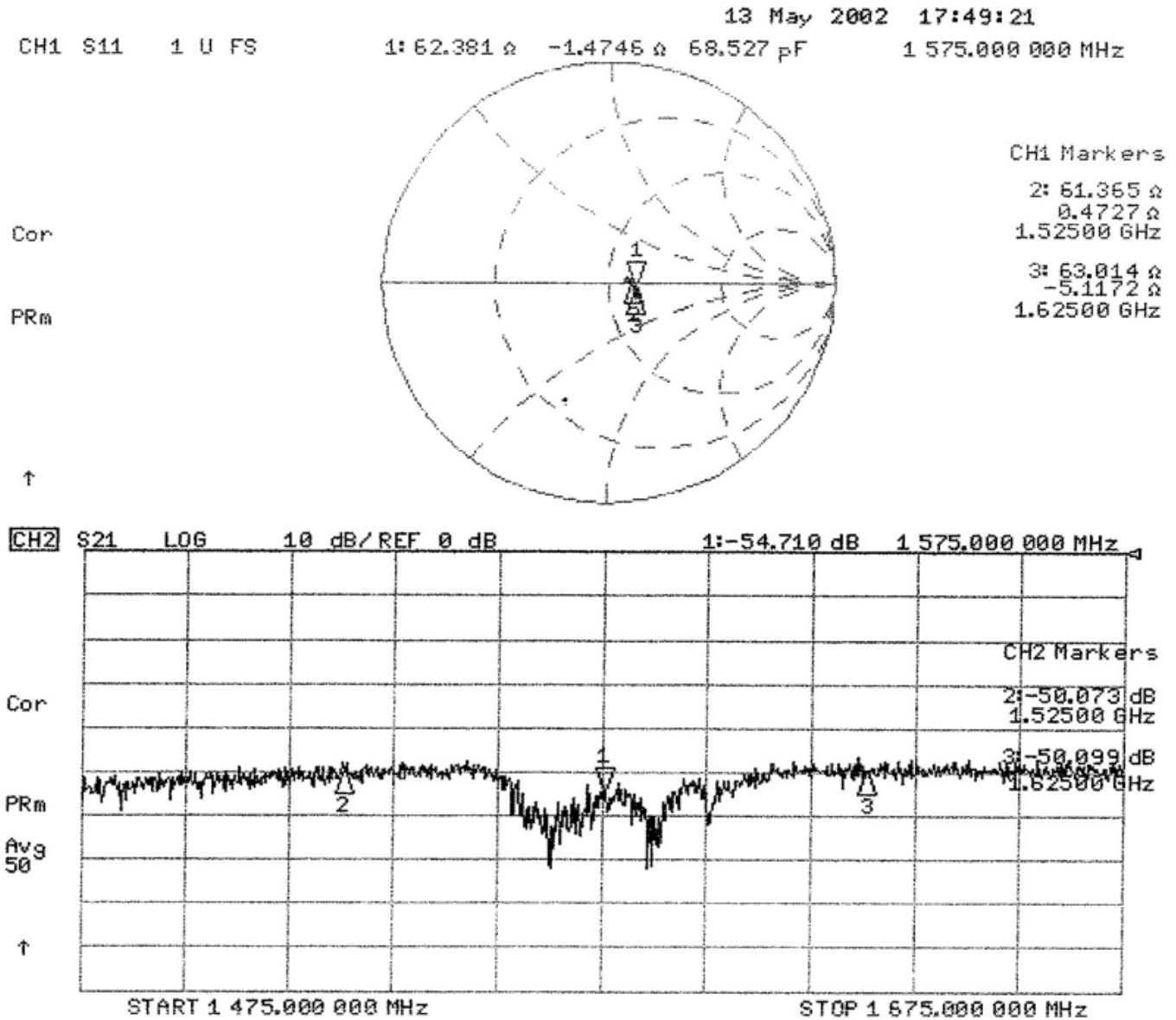

Mechanical

Dimensions: Height: 1.4"
Length (not including connectors) Body: 6.0"
Base Plate: 6.50"
Width (not including connectors): 2.5"
Weight: 16 oz. (450 grams)

Operating Temp. Range: -40° to + 75°C

Finish Housing and Base Plate: ELECTROLESS NICKEL PLATED
MIL-C-26074C CLASS 1, .0001-.0003 MAX
Finish Lid: ANODIZE, TYPE II, CLASS 2, BLACK, per MIL-A-8625

Table with 5 columns: ZONE, REV., DESCRIPTION, REV. BY, DATE. Row 1: -, A, INITIAL RELEASE, -, -

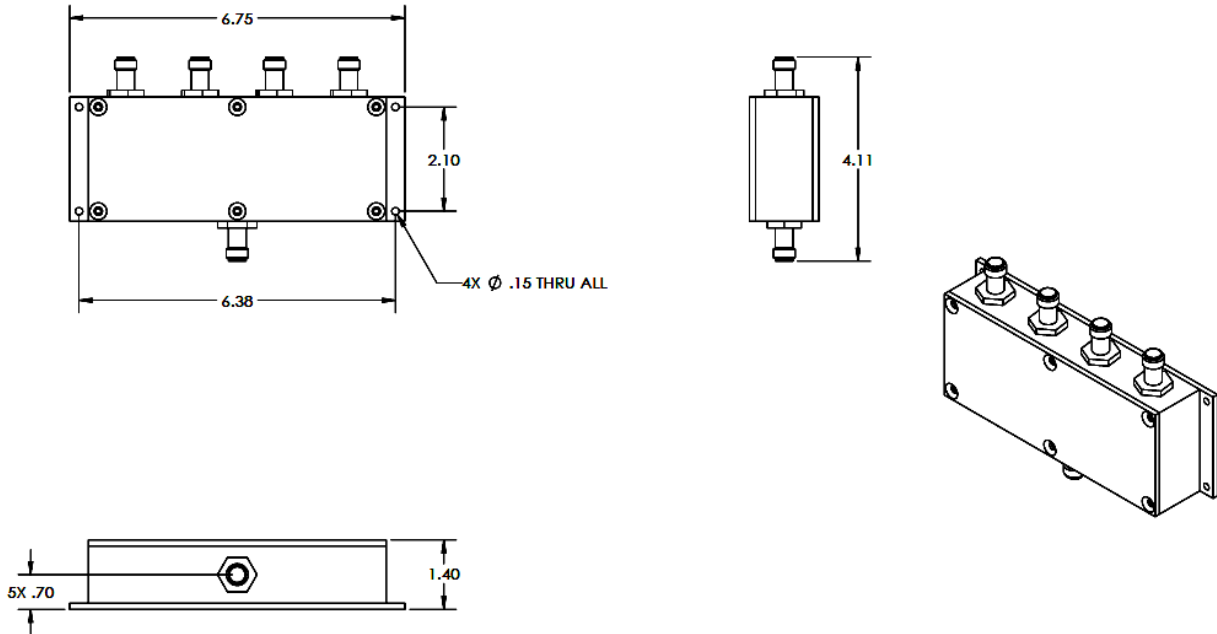

GPS NETWORKING table with columns for title, date, author, checker, etc. Title: Assy, 1x4 LNFA. Date: 08/04/15.